



## Air Vac Cover with Double Door

PART NUMBER

VCDD-1624, VCDD-2436, VCDD-3042

**Features:** Provides vandalism and theft protection for above ground air and vacuum valves.

Double door design allows full access to air valves for maintenance.

Lock hasp handles for district padlock.

28ea. 0.5" Vent holes in 2 rows.

3ea. Anchor legs with 0.5" holes.

**Size:** Available in 3 standard sizes.

**Material:** 10 GA. Steel Construction.  
Stainless steel hinge assembly for corrosion resistance.

**Finish:** Available in zinc rich primer or powder coating in your choice of color.

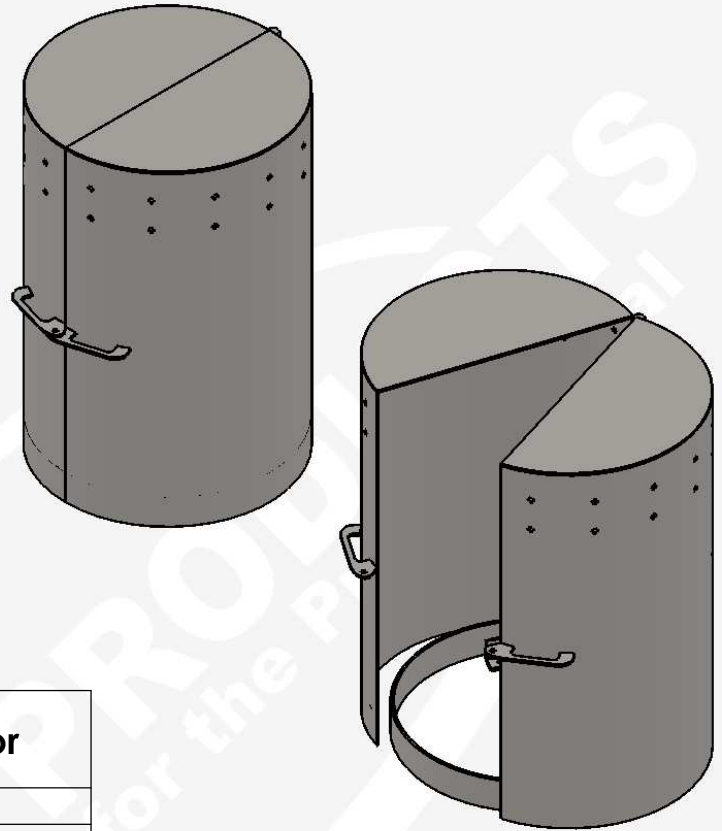

### Air Vac Cover with Double Door

Part No.	"A"	"B"
VCDD-1624	16"	24"
VCDD-2436	24"	36"
VCDD-3042	30"	42"

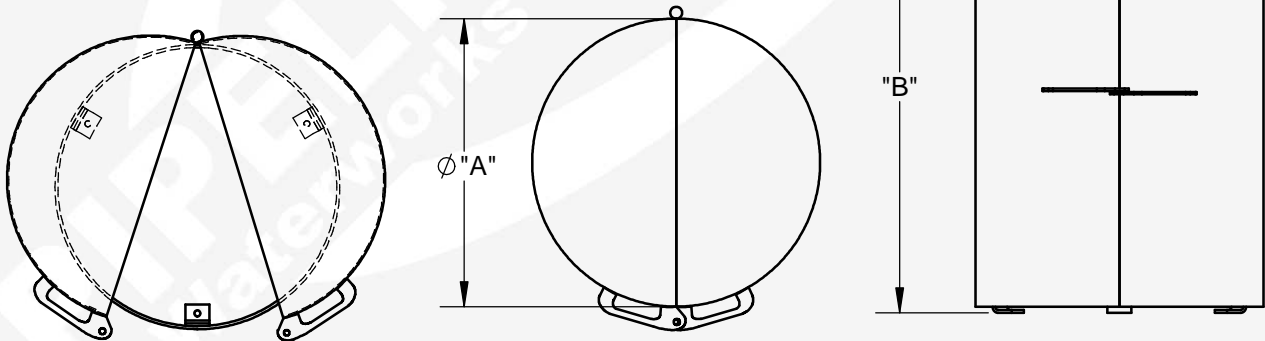

DIMENSIONS ARE IN INCHES | DO NOT SCALE DRAWING | DRW: OSBORNE | REV. A